

Ordering method

FXBYBx - S - A1 - 95 - 55 - 3L - RCX222 - E - N - N1

Model - Cable - Combination - X-axis stroke - Y-axis stroke - Cable length - Controller - Usable for CE - Input/Output Selection 1 - Input/Output Selection 2

A1 to A4 15 to 95 15 to 55 3L, 5L, 10L

Note : For the details of the controller, please refer to the catalog of Yamaha Controllers.

Specification

	X-axis	Y-axis
Motor output	100W	100W
Repeatability ^{Note 1}	+/-0.04mm	+/-0.04mm
Drive system	Timing belt	Timing belt
Ball screw lead/Deceleration ratio	Equivalent to lead 25mm	Equivalent to lead 25mm
Maximum speed	1875mm/sec	1875mm/sec
Moving range	150 to 950mm	150 to 550mm
Robot cable length	Standard : 3.5m Option : 5m, 10m	
Controller	RCX222, RCX142, DRCX0505	

Note 1 : Repeatability for single oscillation.

Maximum load capacity

Y stroke	XY 2 axes
150mm	7kg
250mm	6kg
350mm	5kg
450mm	5kg
550mm	3kg

A1

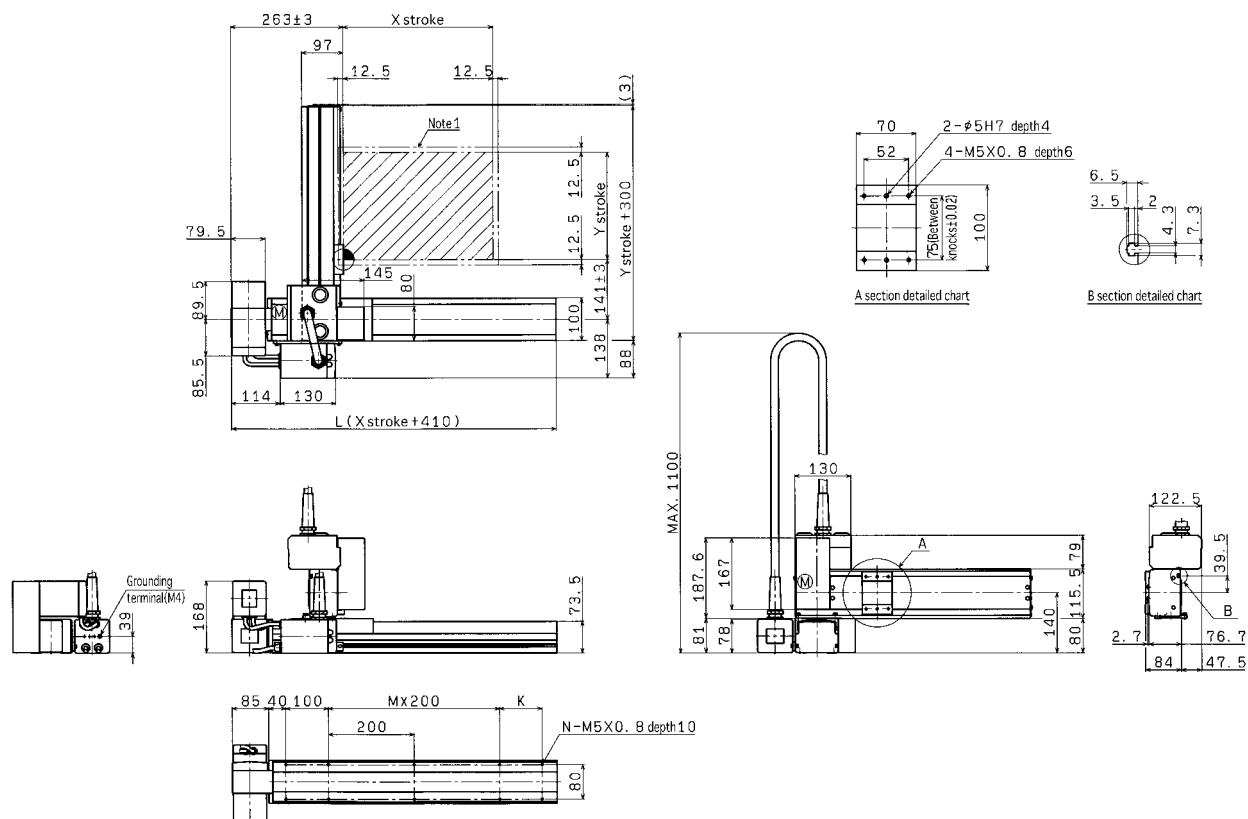

X stroke	150	250	350	450	550	650	750	850	950
L	560	660	760	860	960	1060	1160	1260	1360
K	100	200	100	200	100	200	100	200	100
M	1	1	2	2	3	3	4	4	5
N	8	8	10	10	12	12	14	14	16

Y stroke	150	250	350	450	550
----------	-----	-----	-----	-----	-----

Note 1 : The moving range when returning to origin and the stop position when stopping by the mechanical stopper.

