

Single-axis
robot controller

ERCX

Exclusively for compact model with maximum motor output of 30W.
Extra thin type single-axis controller using 24V DC input power.
Compact and easy to use.



Features

1 Extra thin type of compact size

ERCX comes in as thin as 30mm thickness using the one-board design. As it is the same as SRCX/DRCX in height and depth, it fits in the control panel neatly.

2 Completely absolute

Compatible with absolute position detector resolvers. A function to backup the multi-rotation amount data is provided thereby realizing a completely absolute model.

3 Applicability to network

CC-Link, DeviceNet, Profibus, and Ethernet are available options for easy communication.

4 Two roles with one unit

As a BASIC-like programming language is used, even first-time users can easily program the data. A simple usage method, with no need for programming is possible, by carrying out only point teaching and using movement commands with I/O from the sequencer.

5 Multitask function

This function enables to execute up to 4 tasks of peripheral equipment of the robot at the same time. With the multitask function combined with the JMPP command, it is possible to have I/O output when the specified point is passed during movement.

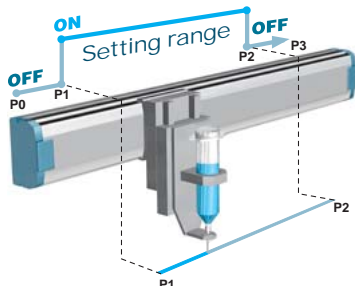

6 Function to make conditional stop during movement

The arm can be decelerated and stopped, using I/O conditions of the MOVF command while it is moving. This function is useful when searching the target position with a sensor.

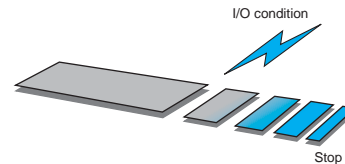

ERCX part names / dimensions

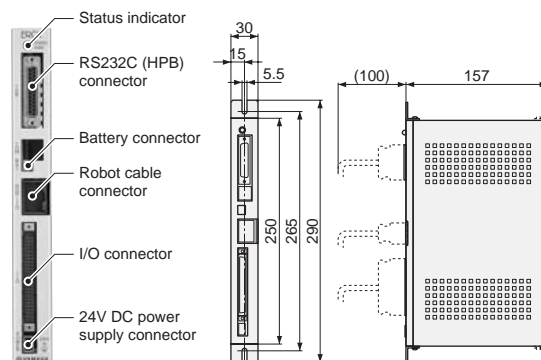

ERCX ordering method

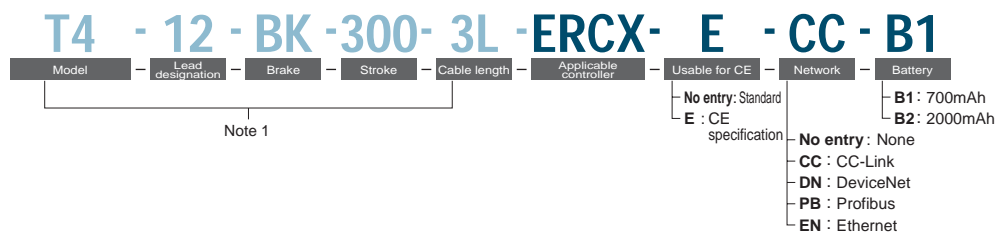

Note 1 : For details of the mechanical section, refer to Yamaha FLIP-X catalog.

ERCX basic specifications

Item	Model	ERCX
Axis control	Applicable motor output	24V 30W or less
	Number of controllable axes	Single-axis
	Number of controllable robots	One single-axis robot (exclusively for T4 / T5 / C4 / C5 / YMS)
	Control system	AC full-digital servo
	Position detection method	Resolver with multi-rotation absolute function
	Position setting unit	Linear system: mm Rotational system : degree
	Operation system	PTP
	Speed setting	1 to 100% in 1% increments
	Acceleration / deceleration setting	1) Automatically set according to robot type and transfer amount. 2) Setting with acceleration/deceleration parameter, 1 to 100% in 1% increments
Program	Program language	Yamaha robot language
	Program capacity	100 programs, 255 steps per program, 3000 steps in total
	Number of multitasks	4 tasks
	Number of points	1000 points in total
	Point-data input method	Manual data input (coordinates input), remote teaching, direct teaching, off-line programming with PC
External input / output	Input/output	16/13 general-use points, 8/3 dedicated points
	External communication	RS-232C : 1CH (for communication with HPB / HPB-D or PC)
	Built-in power supply for external drive	—
Protective function	Brake output	One-point relay type
	Abnormality detection items	Over-current check, over-load check, case temperature check, motor open-circuit check, encoder open-circuit check, software limit over, system malfunction, communication error, battery malfunction
General specifications	Power	DC24V+/-10% 3 to 4.5A (variable depending on robots) ^{Note 1}
	Dimensions	W30 x H250 x D157mm
	Weight	0.9kg
	Ambient temperature	0°C to 40°C
	Ambient humidity	35 to 85%RH (non-condensing)
	Storage temperature	-10°C to 65°C
	Noise resistance capacity	IEC61000-4-4 level 2
Ni-Cd battery charging method	Trickle charging	
Options	Accessories	Power supply connector (1 pc), I/O connector (48-pin) (1 pc)
	Mandatory options	Battery B1 or B2 for absolute data backup
	Selective options	HPB / HPB-D, PC supporting software POPCOM, Communication cable for PC supporting software (3.5m), I/O checker

Note 1 : If a power source of a larger capacity is used, acceleration/deceleration can be improved (up to 4.5A).

ERCX connector I/O signals

Terminal number	Signal name	Function
A-1	ABS-PT	Move the point from the origin position
B-1	INC-PT	Move the point from the current position
A-2	AUTO-R	Start automatic operation
B-2	STEP-R	Start step operation
A-3	ORG-S	Return to the origin
B-3	RESET	Reset
A-4	SERVO	Return to servo on
B-4	LOCK	Interlock
A-5	DI 0	General input 0
B-5	DI 1	General input 1
A-6	DI 2	General input 2
B-6	DI 3	General input 3
A-7	DI 4	General input 4
B-7	DI 5	General input 5
A-8	DI 6	General input 6
B-8	DI 7	General input 7
A-9	DI 8	General input 8
B-9	DI 9	General input 9
A-10	DI 10	General input 10
B-10	DI 11	General input 11
A-11	DI 12	General input 12
B-11	DI 13	General input 13
A-12	DI 14	General input 14
B-12	DI 15	General input 15
A-13	+ IN COM	Controller external+24V power input
B-13	+ IN COM	Controller external+24V power input
A-14	RESERVE	Use by the user prohibited.
B-14	RESERVE	Use by the user prohibited.
A-15	0V	Input/output standard 0V
B-15	0V	Input/output standard 0V
A-16	DO 0	General output 0
B-16	DO 1	General output 1
A-17	DO 2	General output 2
B-17	DO 3	General output 3
A-18	DO 4	General output 4
B-18	END	End normal execution
A-19	BUSY	Executing the command
B-19	READY	Ready for operation
A-20	DO 5	General output 5
B-20	DO 6	General output 6
A-21	DO 7	General output 7
B-21	DO 8	General output 8
A-22	DO 9	General output 9
B-22	DO 10	General output 10
A-23	DO 11	General output 11
B-23	DO 12	General output 12
A-24	ENG 1	Emergency stop input 1, used with EMG2 as a pair
B-24	ENG 2	Emergency stop input 2, used with EMG1 as a pair

ERCX example of input signal connection

When using 24V power supply dedicated for I/O

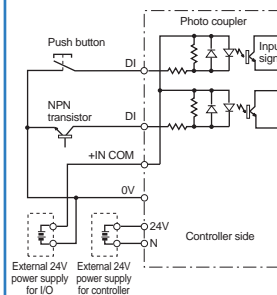

When using 24V power supply for controller as well

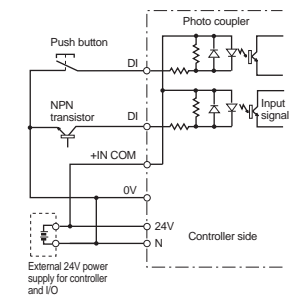

Note : When sharing the power supply, pay special attention to the power supply capacity.

ERCX example of output signal connection

When using 24V power supply dedicated for I/O

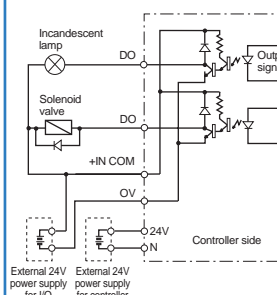

When using 24V power supply for controller as well

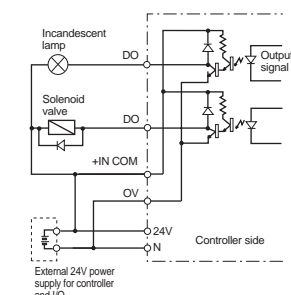

Note : When sharing the power supply, pay special attention to the power supply capacity.

ERCX command list

Command	Function
TON	Start a specified task.
TOFF	End a specified task.
MOVA	Move to a specified point (absolute position movement)
MOVI	Move to a specified point (relative position movement)
MOVF	Move until the specified DI number is entered
JMP	Jump to a specified label of the program
JMPF	Jump to a specified label of the program when conditional jump input matches the set value
JMPB	Jump to a specified label of the program when a DI number input matches the condition
JMPP	Jump to a label designated by axis positioning
CALL	Call another program
DO	Turn general output and internal memory output ON/OFF
WAIT	Wait until the input/output condition is entered
TIMR	Set the standby time
L	Set the location label
P	Set the execution point number
P +	Add 1 to the execution point number
P -	Subtract 1 from the execution point number
ORGN	Return to the origin
SRVO	Turn servo ON/OFF
STOP	Halt execution of the program