

MF50 / MF100 Ordering method

MF50 - RH - 4020 - 3L - SR1 - P - 20 - R - CC - B

Model	Cable carrier take out direction	Stroke	Cable length	Controller	Type	Driver	Regenerative unit	Inputs/outputs options	Battery
	RH : Horizontal, right LH : Horizontal, left	1050 to 4020 (135mm pitch)	3L : 3.5m (Standard) 5L : 5m 10L : 10m	SR1-P SRCP RDP		05 : 100W or less 10 : 200W 20 : 400 to 600W	No entry : None R : Regenerative unit RG1	N : NPN P : PNP CC : CC-Link DN : DeviceNet PB : Profibus YC : YC-Link	No entry : None B : Battery

Note 1 : For details of a controller and driver, refer to Yamaha controller catalog.

MF50D - H - 3700 - 3L - SR1 - P - 20 - R - CC - B

Model	Installation method	Stroke	Cable length	Controller	Type	Driver	Regenerative unit	Inputs/outputs options	Battery
	H : Horizontal installation	730 to 3700 (135mm pitch)	3L : 3.5m (Standard) 5L : 5m 10L : 10m	SR1-P SRCP RDP		05 : 100W or less 10 : 200W 20 : 400 to 600W	No entry : None R : Regenerative unit RG1	N : NPN P : PNP CC : CC-Link DN : DeviceNet PB : Profibus YC : YC-Link	No entry : None B : Battery

Note 1 : 2 units are required when using SR1-P, SRCP or RDP.
Note 2 : For details of a controller and driver, refer to Yamaha controller catalog.

MF100 - RH - 4000 - 3L - SRCP - 30 - R - E - CC - CN1

Model	Cable carrier take out direction (Note 2)	Stroke	Cable length	Controller	Driver	Regenerative unit	Usable for CE	Network	I/O connector specification
MF100 MF100D	RH : Horizontal, right LH : Horizontal, left	MF100 : 895 to 4000 MF100D : 405 to 3510 (135mm pitch)	3L : 3.5m (Standard) 5L : 5m 10L : 10m	SRCP (Note 3)		R : RGU2	No entry : Standard E : CE specification	No entry : None CC : CC-Link DN : DeviceNet PB : Profibus EN : Ethernet	CN1 : I/O flat cable 1m (Standard) CN2 : Twisted-pair cable 2m

Note 2 : For MF100D, cable carrier take out direction is not selectable.
Note 3 : For MF100D, 2 units of SRCP-30-R are required.

MF50 / MF100 Basic specification

Model	MF50	MF100
Driving method	Steel cored linear motor with falt magnet	
Maximum speed (mm/sec)	2500 (Note 4)	
Rated thrusting force (N)	200	400
Maximum thrusting force (N)	600	1200
Maximum payload (Kg)	50	100
Repeatability (μ m)	+/-5	
Support structure	Bearing rail	
stroke (mm)	1050 to 4020 (135mm pitch)	895 to 4000 (135mm pitch)
Width (mm) / Height (mm)	210 / 100	
Scale	Magnetic type: resolution of 1 μ m	
Controller	SR1-P-20-RG1 SRCP-20A-R RCX221-RG2 RCX141-R	SRCP-30-R
Robot driver	RDP-20-RBR1	

Note 4 : Depending on the operation conditions, it may not be possible to use the unit at the maximum speed.

Note : A vertical model (with brake) is not available with the PHASER series.

MF50 Static load moment

Allowable static load moment (N · m)	MY	MP	MR
	3400	3400	4060

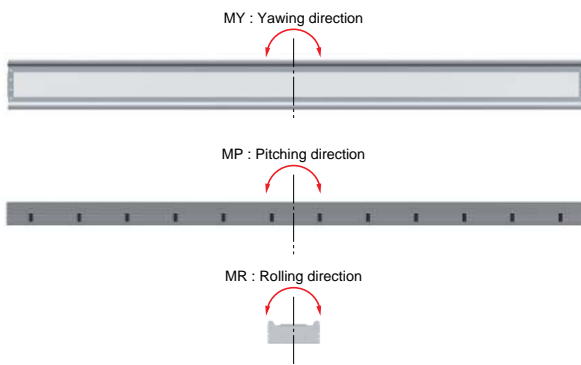

MF50 Allowable overhang (Note 5)

Model	Load	MF50			
		Angle	0°	45°	90°
Horizontal model (mm)	10kg		1900	1900	3900
	20kg		1100	1200	2750
	30kg		800	900	2450
	40kg		600	700	2200
	50kg		500	600	2100

Note 5 : Distance from the center of the top face of the carriage to the gravity center of the item being carried.

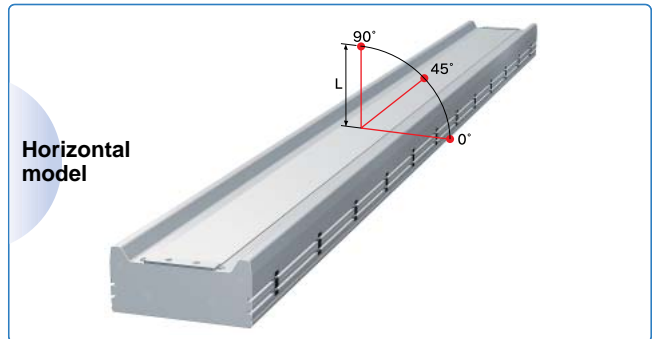

MF50 / MF100 Section drawing of cable carrier

